



EP28LD305

2M USB2.0 HIGH SPEED CAMERA



1.Product feature(产品特性)-----	2
2. SPECIFICATIONS(规格书)-----	3
3. Product（产品尺寸）-----	4
4. Filter wavelength(滤光片光谱)-----	4
5. Cover Proportion（镜头座成份）-----	5
6. Modes of packing（包装方式）-----	5



USB2.0 200 万 80DB 1080P 摄像机

1.Product feature(产品特性)

- 1/2.7" 工业级 200 万高清图像传感器
- 95DB +HDR 电子宽动态，适合复杂的光线环境
- 100°（对角）超广角无畸变高清 500W 像素高清镜头
- 40CM 到无限远清晰成像
- 1500TVL 清晰度
- 固定 30 帧，无拖影
- 0.01Lux（F=1.2）超低照效果
- 0.65W 功耗
- -30°C~+70°C 宽温度范围稳定工作
- 专业 USB-IF WHQL ROHS CE（4KV/8KV）认证（可通过）
- USB2.0 高速传输
- 低带宽需求（62%带宽需求，实现单个平台同时运行 4 个以上摄像机工作）
- 设备名称 厂家 PID&VID 等描述信息多样化定制
- UVC 架构，兼容 Windows XP&7&8.1&LINUX&MAC 多种系统
- 长达 1-5 年的质保期&13 万小时无故障寿命
- 标准 AWM 2725 28AWG/IP 24AWG/2C USB2.0 线(选配 1.3m;2.2m;3m;4.2m)
- 平台最低配置：CPU 1.7GHZ 512MB 内存 40GB 硬盘 XP SP2 系统



2. SPECIFICATIONS (规格书)

Common (简介)

Signal信号	N	P	REMARKS	
Scanning System扫描方式	Progressive scan 逐行扫描			
Scanning Frequency(H)	30HZ	30HZ		
Scanning Frequency(V)	59.9HZ	50HZ		
Image Sensor图像感光片	CMOS	CMOS		
Effective Pixels有效像素	1920*1080	1920*1080		
Pixel size像素点大小	3.0umX3.0um			
Image sensor Data output数据输出类型	Parallel 12bits Raw data			
Video output压缩格式	MJPEG/YUV2			
Maximum Frame Rates分辨率及帧率	1920x1080 at 30fps /1280x1024 at 30fps /1280x768 at 30fps /1024x720 at 30fps /960x540 at 30fps 800x600 at 30fps /640x480 at 30fps/352*288 at 30fps/320*240 at 30fps/160*120 at 30fps		MJPEG	
Maximum Frame Rates分辨率及帧率	1920x1080 at 5fps /1280x1024 at 10fps /1280x768 at 10fps /1024x720 at 10fps /960x540 at 15fps 800x600 at 20fps /640x480 at 30fps/352*288 at 30fps/320*240 at 30fps/160*120 at 30fps		YUY2	
Band with频带	Less then 13% at Windows 7		超低 带宽需求	
SNR max信噪比	≥50Db			
Dynamic range动态范围	≥95Db		(+HDR)	
Min. Illumination 最低照度	0.01LUX		超低照F=1.2	
Outputs format 数据格式	Picture (BMP)/Video (AVI or wmv)		图片/视频	
Digital interface连接接口	5-pin 1.25mm USB2.0			
Transfer rates接口速度	480MB/S			
Power requirements 电源	5V ± 5%			
Power Consumption 功率	Max 0.65w			
Dimensions(PCBA) mm尺寸	28*28		模组	
Weight重量	≤15g		模组	
Operating temperature (°C) 工作温度	-30~70 °C		宽温度范围	
Storage temperature(°C)储存温度	(-40~80 °C) /0~90RH			
Compliance规则	USB-IF WHQL CE RoHS		工业标准设计	
Lens Mount镜头类型	M12X0.5MM			
Lens view 默认镜头	无畸变M12/H=85 °			
Warranty保修	12 month			
OS支持系统	Windows Xp / Vista / Windows 7,8.1/ Mac / Windows 10 / Android / Mac / Linux 2.6.2		多系统兼容	
General Purpose辅助接口定义	1	5V	output(200mA max)	
	2	GND	DGND	
	3	GPIO_0	INPUT	
USB CONN接口定义	1	5V	USB POWER	500mA max
	2	DM	-	D+
	3	DP	-	D-
	4	GND	-	DGND
	5	COVER	-	SHIELD

Attention: 注意:

1. Brightness Sharpness Contrast Hue Saturation Gamma Automatic white balance Back light Exposure can be controlled ; 亮度; 锐度; 对比度; 色温; 饱和度; 伽马; 白平衡; 曝光可以控制;

固化参数	亮度	对比度	色调	饱和度	清晰度	伽玛	白平衡	逆光对比	增益	曝光	镜像
最小值	-64	0	-40	0	0	72	2800	0	0	-13	0
最大值	64	64	40	128	6	500	6500	2	100	-1	3

2. professional SDK support for second develop. 专业的 SDK 支持二次开发

3. VID&PID(公司&产品识别码): 1871& 1130 / ASPIRE*****



3.Product Dimension (产品尺寸)

a. EP28LD305 规格书

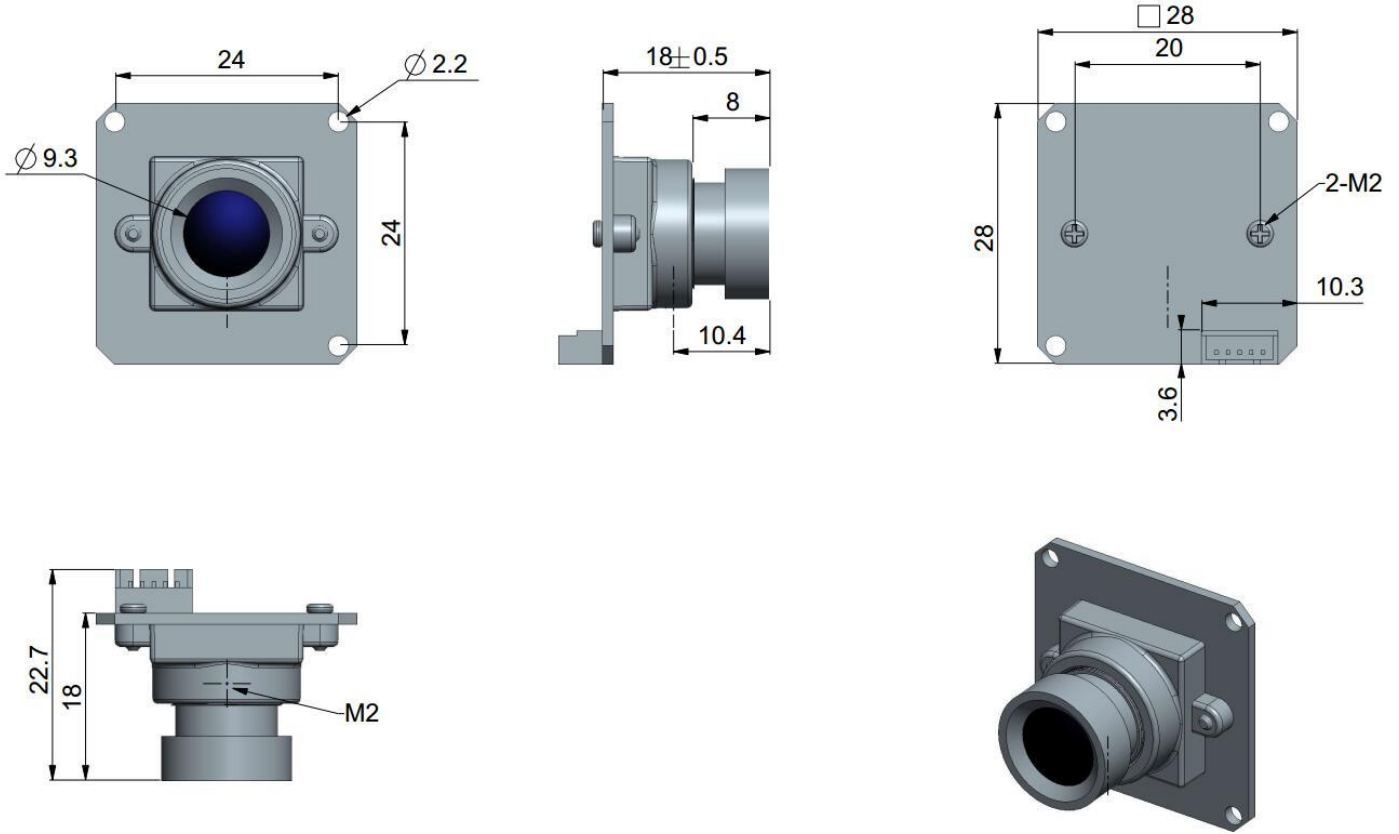

b. USB2.0 data line specification 数据线规格书

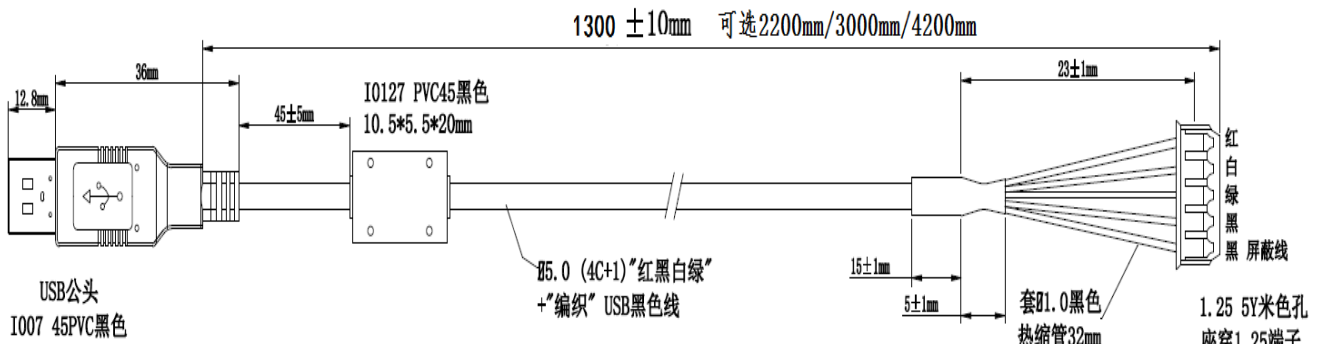

4.Filter wavelength (滤光片光谱)

RGB Filter wavelength (彩色滤光片光谱)

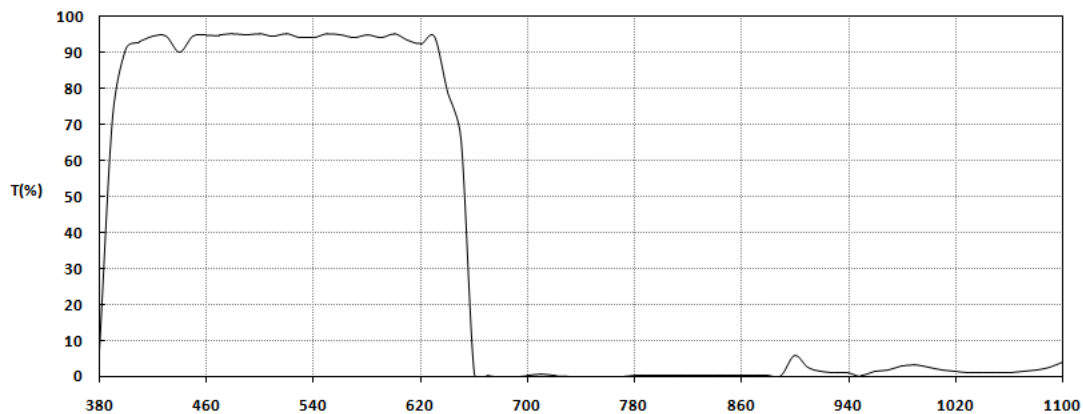

5. Cover proportion(mm) (外壳成份)

NO.	component	Proportion	NOTE
1	ZN	96.2000%	
2	CU	0.0160%	
3	Aluminum	3.7000%	
4	Fe	0.0030%	
5	Pb	0.0025%	
6	Sn	0.0004%	
7	Mg	0.0030%	

6. Modes of packing (包装方式)

